

PVC siding installation

杭州易构建材(浩菲宇鸿)挂板安装程序,先安装附件(外角柱、内角柱、起始条、J型条),再安装挂板。在使用上,外墙挂板是一片紧扣另一片,紧密牢固,功能齐备的各种附件使边缘节点的处理完美无缺。常用的工具有:电锯(台式或手提式)、手锤、细齿直形刀锯、直角尺、水平尺、卷尺、墨线、保护眼镜、工具刀、铁剪子;专用工具有打孔钳、冲孔钳。

PVC siding installation sequence,Installation attachment first(Outer corner,Inner Corner,Start Strip,J-Strip),and then install inside the siding.PVC siding is in used,the was a stick to another,Tight and firm,full of all kinds of accessories make the processing of edge node is perfect. tools:Chainsaw (desktop or portable)、The hammer、The Measuring ruler、The level、A tape measure、Chalk line、protective spectacles、pen knives、scissors;Professional recruitment has punch, punch pliers.



角条的安装 Installation attachment



起始条的安装

Start Strip Install the photo

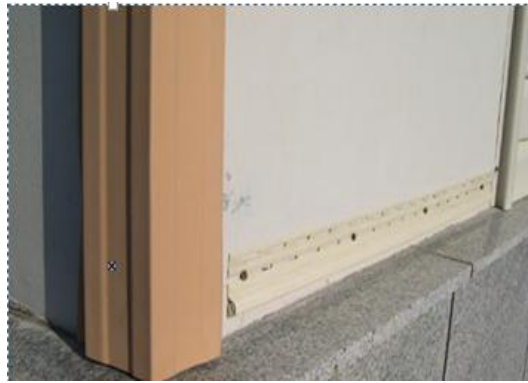

外转角的安装

Outer Corner Install the photo



内转角的安装

Inner corner Install the photo



J型条的安装

J-Strip Install the photo

两张挂板分别割一个小缺口直接拼在一起,这样就不需要用连接条.注:安装时把上下挂板间的拼接缝挂开效果更好
挂板拼接



挂板搭接处理 siding lap processing the photo

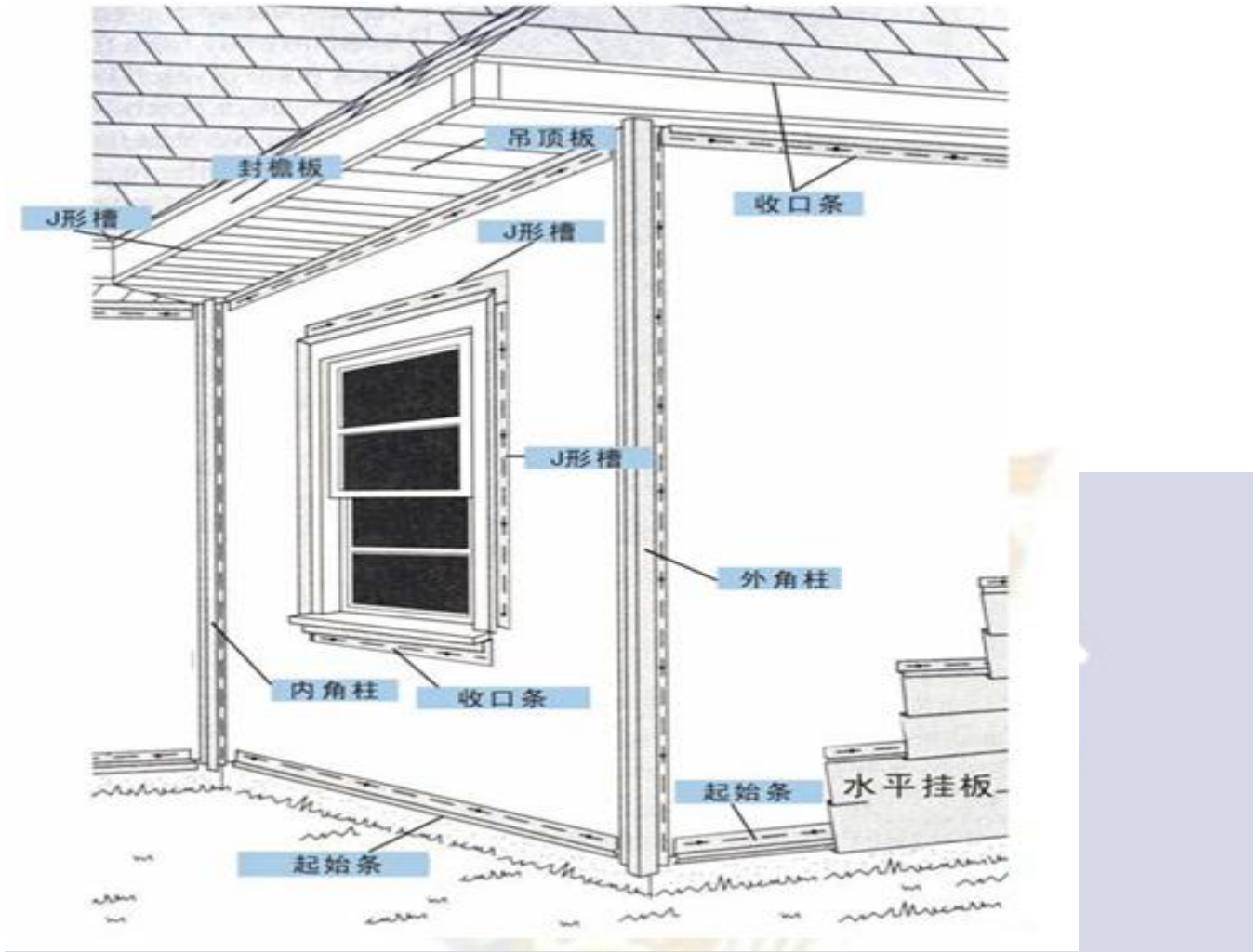

1、弹定位线 Draw positioning line

安装挂板前，必须先弹好线。Before installation, must draw the line

- 在建筑物的每个角，量测从屋檐到被挂板覆盖的最低点

At each corner of the building, Measurements from the roof to the covered by the siding lows

(如：勒角或腰线顶面) 的距离。

- 使用得到的最短距离值为基准，沿墙面弹水平线。用这条线作为起始条

的定位线。

注:确保起始线是水平的。

Using the shortest distance value as the base, Along the wall Draw a horizontal line. (Note: to ensure that the starting line is horizontal.)

2、起始条的安装 (the installation method of Start Strip)

- 沿建筑物的底部安装起始条, 保证起始条的下边缘与定位线重合。

Along the bottom of the building installation the Start strip, ensure the locating and the lower edge of the start of the line.

- 在起始条的每个需安装螺钉的孔中间, 用记号笔作记号, 并取下起始条。
Should be installed in the Start strip of each screw hole in the middle, with a marker pen marked, and remove the Start strip.

- 在作记号处钻孔, 将塑料胀管装人, 再将起始条就位, 在钻孔处钉槽中间拧入螺钉。Drilling in marked place, In the plastic expansion tubes, Put on Start article again, In the middle of the nail hole groove screwed into the screw.

- 当对接起始条时, 应使它们保持至少10毫米的间距, 防止膨胀所引起的变形。When Start strip docking, should keep them at least 10 mm spacing, prevent deformation caused by inflation.

- 起始条同外角柱和内角柱之间留下足够的距离, 一般为75毫米。

The start strip with the left 75 mm distance between Outer corner and the Inner Corner.

- 沿起始条上每400 毫米安装一个螺钉。

In the start strip point distance 400 mm installation of a screw.

3、外角柱的安装 The installation method of Outer Corner

- 外角柱应安装在距离顶部6 毫米处。

The Outer Corner should be installed at the top of the distance of 6 mm.

- 在最上面的钉槽的顶部固定螺钉。固定方法同上，也是先作好记号，装入塑料胀管再将外角柱就位，在钻孔处钉槽中间拧入螺钉。

On the top of the nail groove at the top of the screw. and Installation method as well as starting strip

- 每隔400 毫米安装一个塑料膨胀螺钉。An interval of 400 mm installation screw

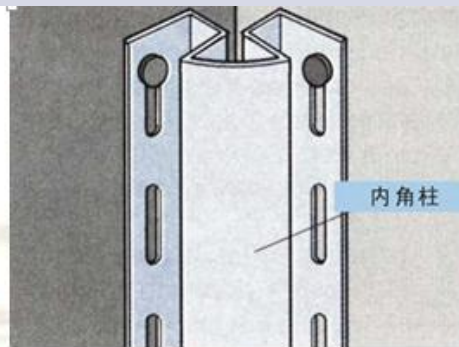
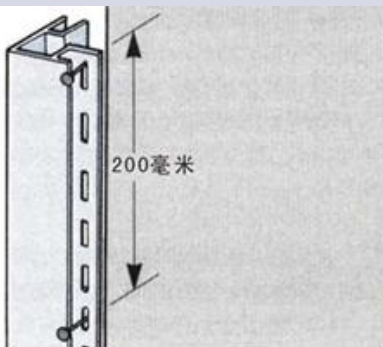

4、内角柱的安装 内角柱的安装同外角柱一样。

注：当一个角柱长度不够，须用几个角柱搭接时，上面的角柱应搭接在下面的角柱之上。并将下面的角柱边缘 剪去25 毫米。

The installation method of Inner Corner is as well as Outer Corner .

(NOTE:When a Outside the prism length is not enough, must use two this, ON Angle should be above the lap joint Angle below. And cut to

25 mm below the edge Angle).

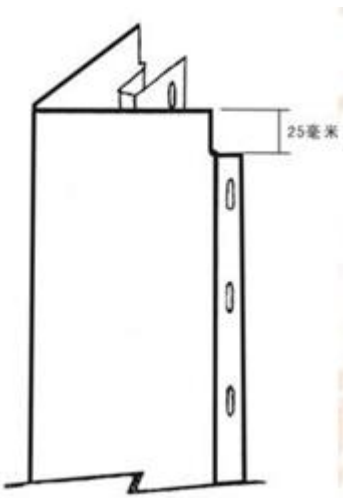

5、门和窗周围的安装 Around the doors and Windows installation method

- 窗子四周用 J 型条安装。根据挂板切割的位置，可能需要在 J 形槽下安装垫片，使 J 形槽和外墙挂板在同一平面。Around the window using the **J-Strip** installation. May according to need in the **J-Strip** groove, the installation gaskets, make J groove and siding in the same plane.
- 安装圆弧窗时, J 形槽事先需加热并弯成同窗一样的弧度。

when Installing a circular window, **J-Strip** tank prior to heating and bending into as the radiant of the circular window.

- 门的安装方法和窗子相同。

Door installation method is the same as the window.

- 阳台板、空调台板周围 J 形槽的安装同窗。The balcony board, the installation of air conditioning bedplate **J-Strip** around the same as the window

6、墙体顶部的安装 在安装挂板前，同样应将山墙顶部的 J 形槽安装好。在山墙顶端，J 形槽交会处，应切 45 度角。

Before wall top mounted Siding, should first **J-Strip** of the tank is installed.

At the top of the mountain, the **J-Strip** (J 形槽) of groove intersection, should cut 45 degree Angle.

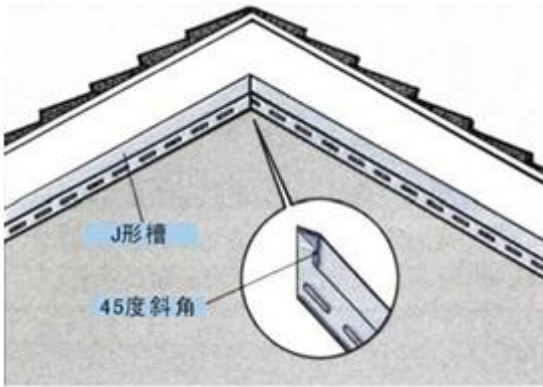

7、挂板的安装 Siding Installation attachment

- 将第一层外墙挂板安在起始板条上，紧紧地咬合。

The first layer of Siding installed on the **Start Strip**, Siding and **Start Strip** must be fastened up.

- 在外墙挂板板端与角柱及门窗边缘J形槽之间预留6毫米的距离。On the edge of the Siding both ends with the **Outer Corner** and the doors and Windows reserved 6 mm distance between **J-Strip**.

- 两块板端应该搭接，搭接长度大约为工厂预制槽的一半（搭接时注意当地的常年风向）
Two boards should end lap, lap length about half the prefabricated groove for the factory. (Lap when pay attention to the local for the direction of the wind)

- 为了美观，每层挂板搭接部分最少互相错开1米，这样一个搭接不会直接在另一个之上。每

4 或 5层，应检查一下外墙挂板是否与屋檐和窗户是否保持平行，是否与其它墙面上的挂板在同一直线上。

In order to beautiful, each layer hangs Taiwan lap part least stagger 1 meter each other, such a lap doesn't directly upon another. When installing siding, often should check the siding parallel to the roof and Windows.



- 当外墙挂板被固定好以后，不要用力向上或向下推它。
When the siding is fixed, not to push it up or down hard.

- 通常，搭接的部分应远离出入口和交通频繁的位置。这样会改善安装的整体外观。
Usually part of the lap joint should be far away from the position of the entrances and frequent traffic. This will improve the installation overall appearance.

8、山墙边端的安装 The top of the mountain type wall installation method

- 斜切外墙挂板来安装没有被覆盖的部分。
Cant cutting wall hangs Taiwan to install is not a part of the cover.

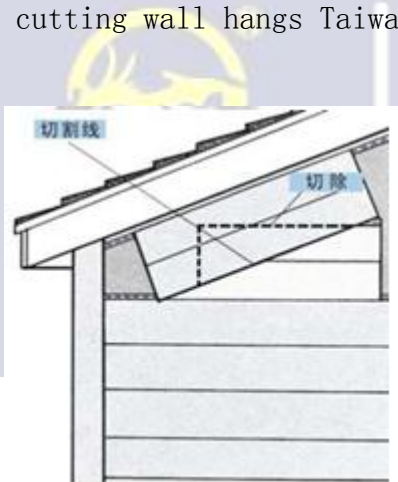

易构建材
YI GOU JIAN CAI

五、Often meet with the installation of different wall graphic

- 1、窗眉 Window brow、窗套 Window Casting、窗台 windowsill 处节点 →

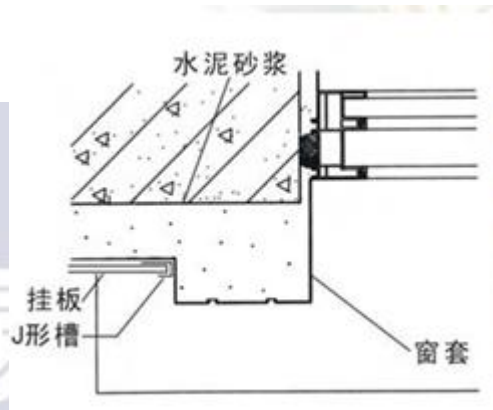
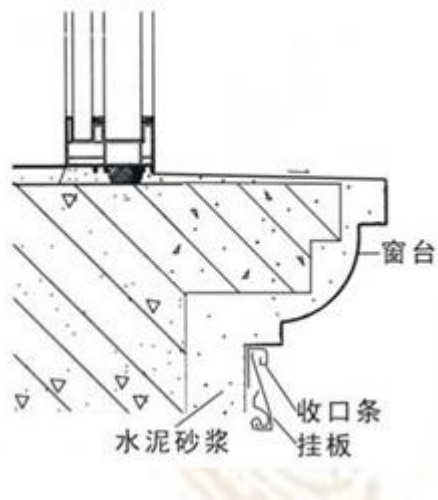
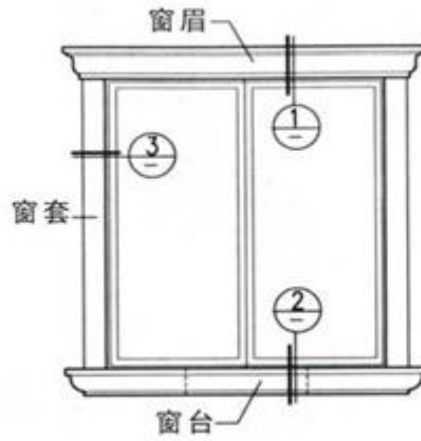
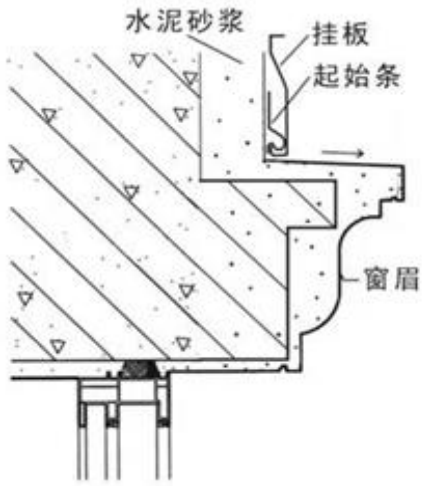

浩菲宇鸿

YI GOU JIAN CAI

2、穿墙管道处节点

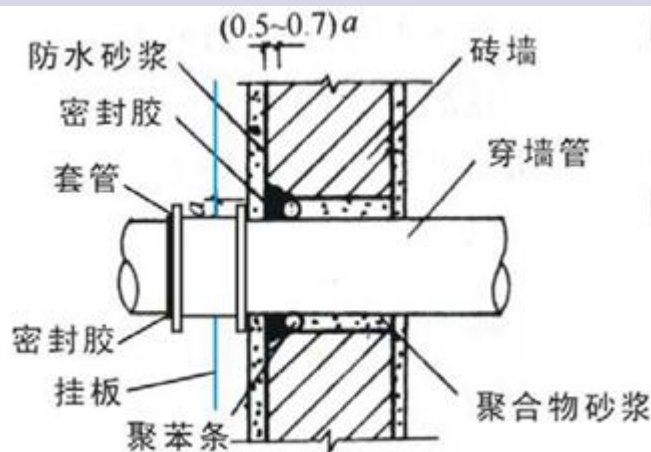

3、门头节点

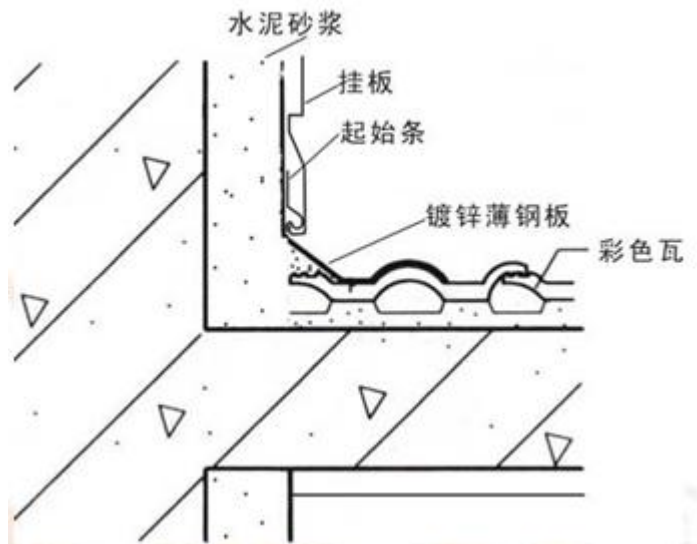

4、腰线处节点

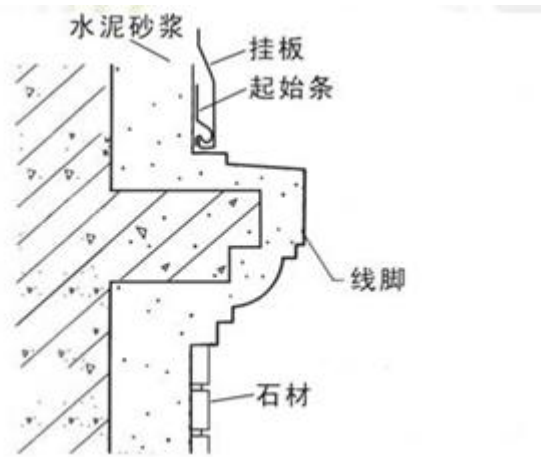

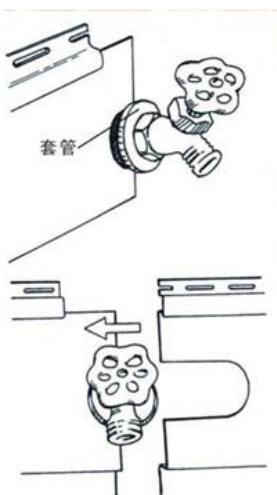

材
YI GOU JIAN CAI

5、墙面突出物

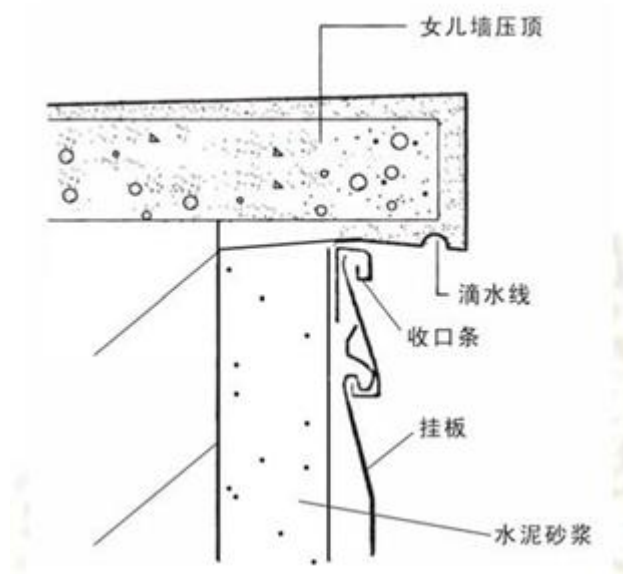

6、女儿墙节点





易构建材

YI GOU JIAN CAI

六、安装时的注意事项 The matters needing attention during installation

- 除竖向构件的最上面一个螺钉应位于钉槽的顶端外, 其余螺钉均钉在钉槽的中间

In addition to the vertical component of the top a screw should be fixed on the top of the nail groove, the rest of the screws are in the middle of the nail groove.

- 螺钉不要拧得太牢。考虑到挂板的胀缩, 钉帽同挂板之间留0.8毫米的距离。当挂板被固定以后, 用手按住挂板, 应该能够左右移动。

Screw don't too fast. Considering the swell-shrink siding, head of nail with siding between the distance of 0.8 mm. When siding are fixed with the hand holding the siding, should be able to move around.

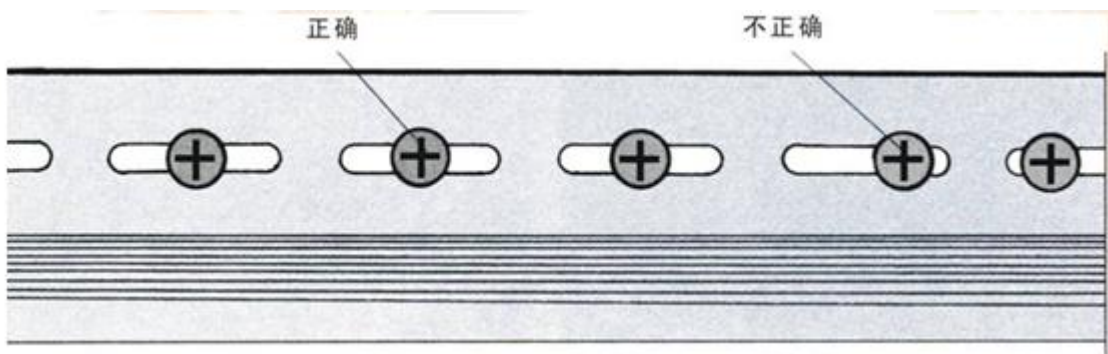

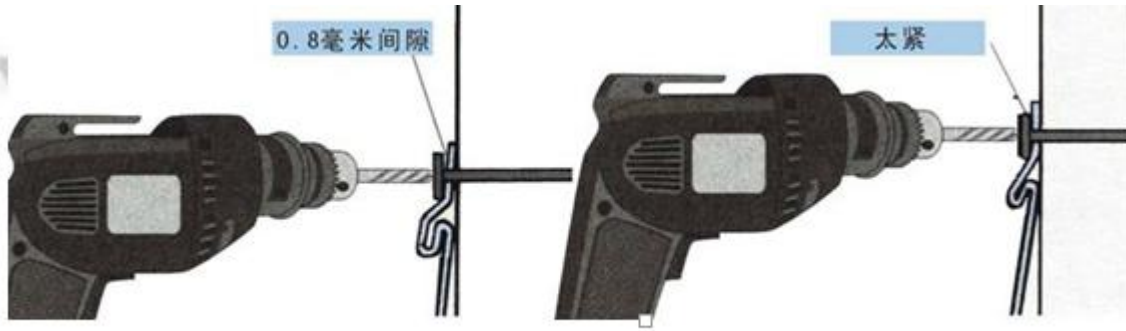

- 螺钉不能直接钉在挂板面上。如果没有钉槽，用钉眼冲孔器做一个。

Screw can not directly on the siding. If there is no nail groove, made a nail hole punching machine.

- 螺钉要垂直钉入。不要使钉子弯曲，否则会限制挂板自由移动。如果钉得偏上或偏下，挂板可能会被偏离校准直线。

Screw must be vertical nail into. Don't bend, otherwise it will limit siding move freely.

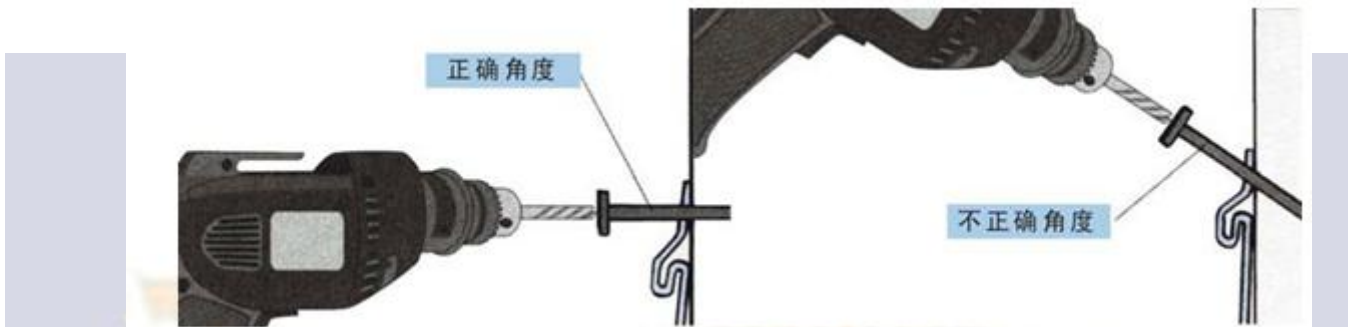

- 每安装完一片挂板，检查挂板下边是否与下一层挂板扣牢，且不要太松或太紧。

When installed a Siding, must check the underneath and the next layer of Siding lock-in, not to be too loose or too tight.

